

Differences between sprint tests under laboratory and actual cycling conditions

W. BERTUCCI^{1,2}, R. TAIAR², F. GRAPPE¹

Aim. The aim of this study was to compare the maximal power output (PO_{peak}) and force-velocity relationships in sprint cycling obtained from a laboratory protocol and from a field test during actual cycling locomotion.

Methods. Seven male competitive cyclists performed 6 sprints (3 in the seated position and 3 in the standing position) on an ergo-trainer (Tacx, Netherlands) and 6 sprints during actual cycling locomotion in a gymnasium. The bicycle was equipped with the SRM Training System (Schoberer-Rad Messtechnik, Germany) to measure (200 Hz) the power output (PO, W), the pedalling cadence (rpm), and the velocity ($km \cdot h^{-1}$). From these measurements, the maximal force on the pedal (F_{max}), the theoretical maximal force (F_0 , N) and the theoretical maximal pedalling cadence (V_0 , rpm) were determined. During each sprint test the lateral bicycle oscillations were measured from a video analysis.

Results. During standing and seated sprints in the gymnasium, F_0 and F_{max} were significantly higher ($p < 0.05$) compared with sprints on the ergo-trainer (+12% and +32%, respectively). The PO_{peak} during sprints in seated and standing positions in the gymnasium was significantly ($p < 0.05$) lower (-4%) and higher (+6%) respectively, compared with the ergo-trainer. For standing position in the gymnasium the kinematics analysis indicated a 24° mean lateral bicycle oscillation compared with 0° on the ergo trainer.

Conclusion. The results of this study indicate that PO_{peak} , F_0 and time to obtain PO_{peak} were different between laboratory and actual cycling conditions. To obtain a valid estimation of the maximal power output, it is necessary to perform sprint tests during actual cycling locomotion. Thus, in the laboratory, it is advisable to use a cycle ergometer that enables natural lateral oscillations.

KEY WORDS: Cycling - Maximal power output - Field test - Laboratory test.

¹Laboratoire de Mécanique Appliquée (U.M.R. C.N.R.S. 6604) UFR STAPS

Université de Franche Comté, Besançon, France

²Laboratoire d'Analyse des Contraintes Mécaniques (LACM, EA 3304) UFR STAPS

Université de Reims Champagne-Ardennes, Reims, France

The difference between the winner and the 2nd second placed cyclist for track cycling is very small. During the 2002 world track championship (Ballerup/Copenhagen, Denmark, 2002) in the 1 000 m time trial, the difference between the first and the second cyclist was only 0.001 s. For track cycling competitions the capacity to produce a high peak power output (PO_{peak} , W) is a major determinant of the performance. Several studies¹⁻³ have shown that the ability to produce the highest PO_{peak} at the start of the track competition (1 000 m and 4 000 m time trial) corresponds to the optimum race strategy. The time of the first lap (250 m) of the 1 000 m time trial was highly correlated to the final time. The capacity to produce a high PO_{peak} depends essentially on the force-velocity relationships of the cyclist. Thus, it is important to measure the PO_{peak} , the speed of the rider and the force applied on the pedal in order to optimise the performance (for example to determine the optimal gear ratio).

Several protocols have been used to measure the PO_{peak} of the lower limb: force-velocity tests on the cycle ergometer,⁴ jump tests, squat jump, counter movement jump,⁵ and staircase.⁶ On ergometer tests,

Address reprint requests to: Dr. W. Bertucci, Laboratoire d'Analyse des Contraintes Mécaniques/UFR STAPS, Bat 6 moulin de la Housse, 51687 Reims cedex 2, France. E-mail: william.bertucci@univ-reims.fr

TABLE I.—Anthropometric characteristics of the subjects.

Variables	Mean	SD	Range
Age (years)	22	4	18-27
Height (cm)	179	5	171-184
Mass (kg)	71.2	7.7	61-81.1
Relative body fat (%)	12.3	2.8	9-16
Distance to training (km)	9 429	1 988	7 000-12 000

PO_{peak} is obtained at combined optimal values of force (N) and pedal velocity ($rad\ s^{-1}$). Martin *et al.*⁷ have also shown that for the cycle ergometer, the crank length, and pedalling cadence were important determinants of the PO_{peak} .

Recently, both scientists and coaches have developed and employed mathematical models to estimate the PO requirements of different track cycling events.⁸⁻¹¹ These models have taken into account the kinetic energy variations and the metabolic energy production system (aerobic and anaerobic).^{2, 3} However, they are more suitable to estimate the PO at steady state velocity. Craig *et al.*¹ used the SRM crank dynamometer (Schoberer) to measure the PO, the cycling velocity ($m\ s^{-1}$), the pedalling cadence (rpm), and the heart rate ($beats\ \cdot\ min^{-1}$). They have shown that during a 200 m flying qualification sprint at a world cup event, the PO_{peak} and mean power output (PO_{mean}) generated by a female cyclist was 1 020 and 752 W, respectively. Moreover, at the end of the 200 m, PO was 568 W, which equates to a 44% drop from the peak power. The peak velocity and pedalling cadence was 63.5 $km\ h^{-1}$ and 150 rpm,¹ respectively. To the best of our knowledge, there is no sprint test protocol to estimate PO_{peak} in actual cycling locomotion (on the track) without using a crank dynamometer like the SRM system and no study has shown the accuracy between the PO_{peak} measured in laboratory and in actual cycling locomotion.

We hypothesised that the mechanical variables obtained with the sprint tests on an ergo-trainer were different compared with those in the actual cycling locomotion. This study can be divided into 2 parts. In the first part we have compared the mechanical variables obtained with the SRM crankset powermeter during a standard laboratory protocol for PO_{peak} determination, with those from a field test that measures the PO_{mean} and PO_{peak} in actual cycling locomotion. In the second part we have determined the relationships between the different mechanical variables and the equation which computes PO_{mean} by considering only

the variation of the kinetic energy of the accelerating cyclist over the sprint distance. Thus the aims of this study were to determine; 1) if the laboratory standard protocol can provide valid results when compared with the field protocol, and 2) if the equation based on classical dynamics can provide valid results when compared with the SRM measurements.

Materials and methods

Subjects

Seven male competitive cyclists ranging from regional to national level volunteered to take part in this experiment. Each subject was informed of all the test details and signed an informed consent. All subjects were well trained at the time of the experiment, which was conducted at the end of their competition period. Table I shows the main individual characteristics of the subjects.

Instrumentation

During this study each subject rode on a classic race type bicycle (9 kg) equipped with "clipless" pedals, race saddle, and race handlebars. The bicycle tyre pressure was inflated to 700 kPa. Before beginning the test, the cyclist adjusted the bicycle to his usual cycling position. The bicycle used for all tests was equipped with the SRM Training System (professional model, Schoberer Rad Messtechnik, Germany, 2% accuracy). The SRM device is a precision strain-gauge-based crank and sprocket dynamometer that radio-transmits data to a unit display fixed on the handlebars. The SRM sampled (10 Hz) and stored the PO, the pedalling cadence (rpm) and the velocity ($km\ h^{-1}$). The validity of the SRM has been previously demonstrated by Martin *et al.*,¹⁰ Jones¹² and Passfield *et al.*¹³ Before the experimental procedure, the SRM was calibrated according to the manufacturer's recommended procedures. The test in the laboratory conditions was performed on a classic race type bicycle using an ergo-trainer T1670 Basic (Tacx, Netherlands). The resistance on this ergo-trainer was obtained by an electromagnetic brake applied to a roller in contact with the rear wheel. In this study all maximal PO tests were performed on the highest brake of the ergo-trainer. A front wheel support was used in order to permit cycling in horizontal position.

Test protocol

The study included 12 sprint tests. After a standardised warm-up, the subjects performed 6 tests under laboratory conditions (on a Tacx ergo-trainer) and 6 tests in a gymnasium (55 m length) with actual cycling, from a static start. Under each laboratory and actual cycling condition the cyclists performed 3 tests in the seated position and 3 tests in the standing position. In the seated and standing positions the subjects performed in a randomised order 3 sprints on ergo-trainer against 3 different resistive loads (0.4, 0.6, 0.8 N/kg). The determination of the gear ratio according to each resistive load was performed during a short exercise (<15 s) according to the subject's mass and a computed PO reached on the SRM' screen display at a given pedalling cadence according to the method of Ravier *et al.*^{14, 15}

In actual cycling locomotion (gymnasium), the gear ratio's according to the 3 different resistive loads were determined with computations of crank inertial loads of 40, 55 and 80 kg m². The crank inertial load was computed from the equation elaborated by Fregly *et al.*¹⁶

Crank inertial load:

$$I_f + (R_f/R_g)^2 [R_d^2 (m_a + m_c + 2m_d + m_f + m_g) + (2I_d + I_g)] \quad (3)$$

With: m_a , m_c , m_d , m_g : respectively mass of the bicycle frame (5.8 kg), the rider, each bicycle wheel (1.18 kg), and the freewheel (0.32 kg), respectively; m_f : mass of the chainrings, crank arms, and pedals (1.66 kg); I_d : rotational inertia of each bicycle wheel about its rotation axis (0.1366 kg m²); I_f : combined rotational inertia of the chainrings, pedals, and crank arms about the crank axis (0.0355 kg m²); I_g : rotational inertia of the freewheel about its rotation axis (0.0003 kg m²); R_d : radius of each bicycle wheel (0.3429 m); R_f/R_g : gear ratio.

In this condition the crank inertial load represents the cyclist inertial resistance and in other words "the resistive load" for the sprints in the actual cycling locomotion. The subject performed a 10 min standardized warm-up period before the first test. Tests in the gymnasium were performed over a distance of 25 m. Before the beginning of this test the subject clipped his pedal and was maintained horizontally by an experimenter. The start was given by verbal command. The subjects were rigorously encouraged to reach the PO_{peak} as soon as possible. The recovery period between all trials was 5 min. The cyclist chose the

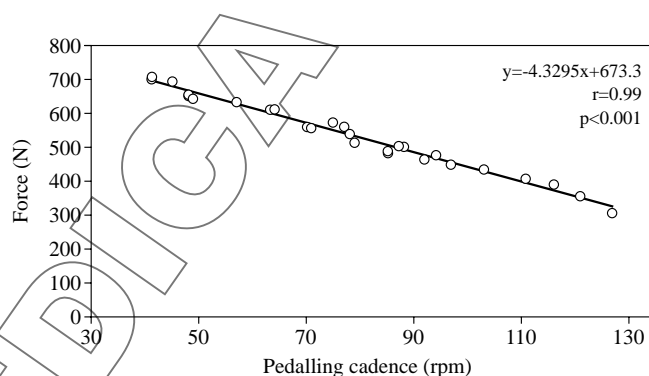

Figure 1.—Typical force velocity relationship determined for one subject during sprints in the gymnasium.

same lower limb position for the start of all sprint tests (crank arm with a 45° crank angle and pedal in front position).

Mechanical variables measured

The PO, the pedalling cadence, and the cycling velocity were measured according to the time (200 Hz). The mechanical variables were thereafter averaged every 0.1 s. The PO_{peak} was determined by the maximal value measured by the SRM system. From this measurement, the maximal force on the pedal (F_{max}) was determined:

$$F_{max} = PO / [\text{crank arm length (m)} \times \text{pedal velocity (rad}\cdot\text{s}^{-1})] \quad (1)$$

The pedalling cadence and force values were used to calculate the force-velocity relationship (Figure 1). According to the recommendations of Buttelli *et al.*,¹⁷ the first value made at very low pedalling cadence was not taken into account in order to calculate the force-velocity relationship.

V_0 and F_0 values were determined from this relationship (Table II). V_0 represents the theoretical maximal pedalling cadence (with no resistive load), and F_0 represents the theoretical maximal force of the cyclist.

In order to determine estimated PO during the sprint tests on the gymnasium we used a basic fundamental equation. The PO produced by a cyclist during the acceleration phase (from a static start) can be obtained from the derivative of energy expenditure ($PO = \frac{de}{dt}$).

Our hypothesis considered only kinetics energy, and neglected aerodynamics and rolling resistance.

TABLE II.—Mechanical variables in seated and standing positions on the ergo-trainer and in the gymnasium conditions.

	Ergo-trainer Seated position	Ergo-trainer Standing position	Gymnasium Seated position	Gymnasium Standing position
PO _{peak} (W)	881±135	913±149	843±137 a	973±153 bc
Time to PO _{peak} (s)	1.78±0.73	1.57±0.63	2.96±0.54 a	2.69±0.7 bc
Cadence at PO _{peak} (rpm)	139.2±18	133.2±13 a	93.6±16 a	96.6±16 b
F _{max} (N)	465±64	471±69	661±110 a	722±116 bc
F _o (N)	720±95	745±100	800±112 a	857±154 bc
V _o (rpm)	262±29	259±35	248±48	281±68

a: different (P<0.05) to seated position on ergo-trainer; b: different (P<0.05) to standing position on ergo-trainer; e: different (p<0.05) to seated position in the gymnasium.

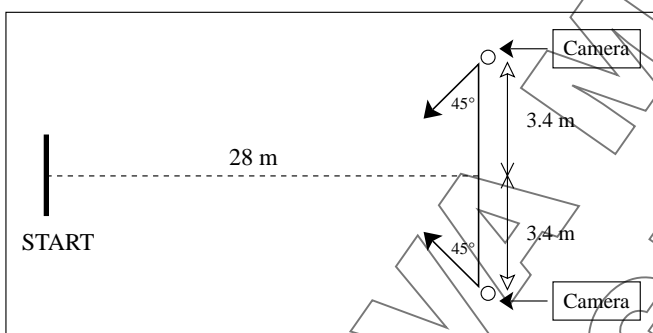

Figure 2.—Position of the cameras in the gymnasium.

stationary to 3.40 m of the axis of race and to 28 m of the start line. The optic axis of each camera formed an angle of 45°, therefore in the line with the axis of the cyclist's displacement (Figure 2).

Video data treatment

The video images were numerised with a pinnacle studio DV8 card. The images were digitised using the Kinematic software (3D Vision). For each frame, 16 points on the cyclist body (tips of the middle fingers, elbows, shoulders, ankles, knees, toes) and 4 points on the bicycle were semi-manually digitized. In this study only the 4 points of the bicycle were taken. These points were studied in order to observe the influence of the different bicycle oscillations on the athlete's performance.

Statistics

The mechanical variable values of the 3 sprints for 1) seated on ergo-trainer 2) standing on ergo-trainer, 3) seated in gymnasium and 4) standing in gymnasium were averaged. A Wilcoxon matched-pairs test was used to determine differences in mechanical variables between the different experimental conditions: 1) gymnasium vs ergo-trainer, 2) seated position vs standing position. Regression analyses were used to estimate the relationships between the mechanical variables (force-velocity, PO_{peak}-PO_{mean}, estimated PO_{mean}-actual PO_{mean}). Bias, limits of agreement and 95% confidence interval (95% CI)^{18, 19} were further estimated in order to quantify the differences between estimation of PO by the basic physical equation and SRM measurements. Significance was set at p<0.05. Data are presented as mean values±standard deviation.

To estimate the PO_{mean}, the final equation is:

$$\text{Estimated PO}_{\text{mean}} = \frac{1}{2} m a V \quad (2)$$

With m, the mass of the bicycle and the cyclist, V the maximal velocity obtained at the end of the test (at 25 m, after static start), and a the mean acceleration of the cyclist (between 0 to 25 m), a was determined from the following equation: a=V/(time of the sprint [s]). V and the time of the sprints were obtained from the SRM measurements.

Kinematics analysis

The sprint tests were videoed by 2 cameras (JVC DVX-400EG marks) at a frequency of 25 Hz with a speed of 4 000th of a second shutter speed on a numeric support. The simultaneous registration of both cameras was achieved with an infrared remote control. For the picture video we used the frame field to get 50 pictures per second. Both cameras were on each side

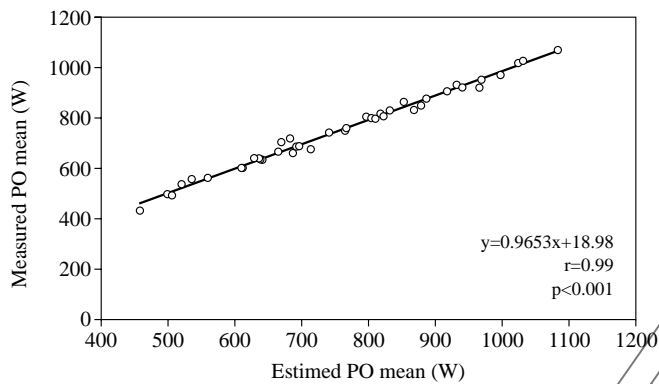

Figure 3.—Relationship between the SRM PO_{mean} measurement during sprints in the gymnasium and PO predicted by the mathematical model.

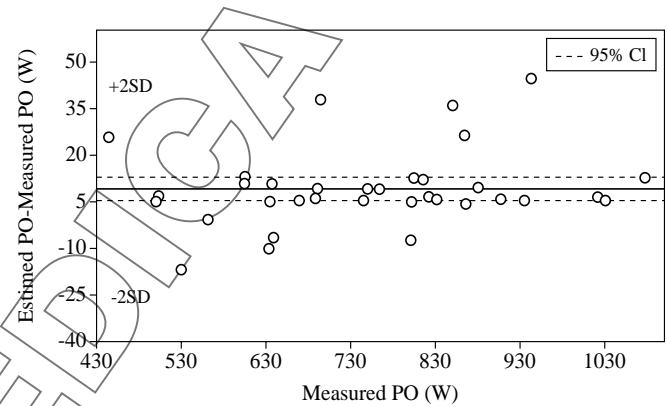

Figure 4.—The limits of agreement of the SRM PO and the estimation PO obtained from the basic equation during the field sprint tests.

Results

During sprints for both standing and seated positions in the gymnasium, F_o , F_{max} , and time to PO_{peak} were significantly higher ($p < 0.05$) compared with sprint on ergo-trainer (Table II). However, the PO_{peak} during sprints in seated and standing positions in the gymnasium was significantly ($p < 0.05$) lower (-4%) and higher (+6%) respectively, compared with ergo-trainer. F_o , PO_{peak} , and F_{max} during the sprints in seated position in the gymnasium, turned out to be significantly lower ($p < 0.05$) compared with the values obtained in the standing position. For sprints on ergo-trainer, only the pedalling cadence was different between the seated and standing positions.

The linear force-velocity relationships in the different experimental conditions were obtained with correlation coefficients (r) between 0.86 and 0.99 ($p < 0.05$).

The relationship between the PO_{mean} measured during the sprints in the gymnasium and the estimated PO_{mean} (obtained with the basic physical equation) was obtained with a correlation coefficient of 0.99 ($p < 0.001$), (Figure 3). The PO_{mean} measured during the sprints in the gymnasium was close to the estimated PO_{mean} (746 ± 159 vs 756 ± 161 W, respectively). The basic physical equation over-estimates PO measurements only by $1 \pm 0.02\%$. The limits of agreement between the estimated PO_{mean} and SRM PO during the sprint test are presented in Figure 4. The mean PO difference between estimated PO_{mean} and SRM $PO \pm 1.96$ SD (calculated bias), was: 8.96 ± 24.52 W. The 95% CI for the mean differences in PO measure-

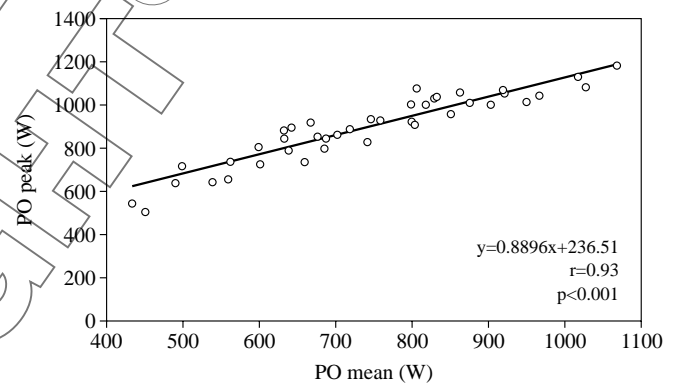

Figure 5.—Relationship between the PO_{mean} and PO_{peak} during the sprints in the gymnasium conditions.

ments are between 5.08 and 12.84 W. Seventy percent of data points lay inside this interval.

In our study the PO_{mean} and PO_{peak} were linked (Figure 5) with a high correlation coefficient ($r = 0.93$, $p < 0.001$). PO_{peak} was 20% higher ($p < 0.05$) compared with the PO_{mean} (902 ± 150 W vs 748 ± 157 W, respectively). The relationship between these 2 variables was determined by the following regression equation:

$$PO_{\text{peak}} = 0.8896 PO_{\text{mean}} + 236.5 \quad (3)$$

The kinematics analysis showed that the lateral oscillations of the bicycle during the test sprints in the gymnasium were 6.1 ± 1.2 and 24 ± 2.1 ($p < 0.05$) in seated and standing positions, respectively (Figure 6). However, lateral oscillations during sprints on ergo-trainer were close to 0° .

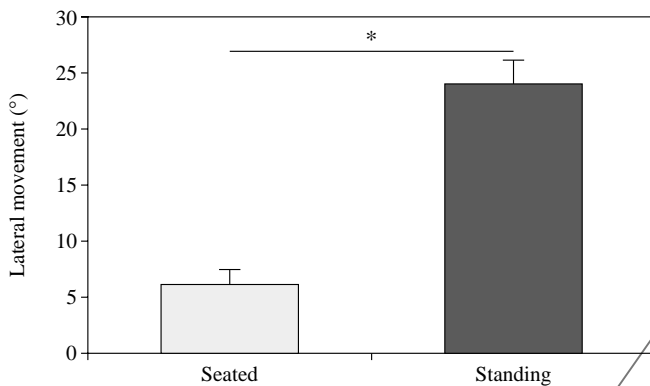

Figure 6.—Bike lateral oscillations during the sprints in the gymnasium. * $p < 0.05$. Brackets represent one standard deviation.

Discussion

The first aim of this study was to compare the mechanical variables obtained during sprints on ergo-trainer and in the gymnasium conditions. The most important finding of this study indicates that during sprints in the gymnasium in standing position, PO_{peak} , F_o , F_{max} , and time to PO_{peak} were higher compared with sprints on ergo-trainer. During the sprints in the gymnasium the cyclist was naturally able to allow lateral oscillations (Figure 6) close to 25° , contrary to ergo-trainer conditions. Thus, in standing position, the cyclist was able to orient his lower limbs with respect to the pedal and crank arm.²⁰ In this condition the cyclist can apply a more perpendicular force to the crank arm, and thus create a greater propulsive force when compared with the ergo-trainer conditions. On ergo-trainer there is no significant difference in PO_{peak} and F_{max} between the seated and standing positions, but there is a difference ($p < 0.05$) in the gymnasium (Table II). These results suggest that the possibility to laterally oscillate the bicycle is a factor that can improve the performance during the short time sprint exercise in standing position. That is in agreement with the results of Reiser *et al.*²⁰ and Baker *et al.*²¹ who have demonstrated the effective role of the arms and upper body in the mechanics of cycling. Baker *et al.*²¹ have shown that PO_{peak} during 20 s sprint on an ergometer was significantly ($p < 0.05$) lower (-28%) when the cyclist was not able to use the traditional grip on the handlebars. This study indicated that the handgrip strength influenced the leg PO_{peak} and can permit the cyclist to increase the force on the pedal by pushing or pulling actions on the handlebars.

However, in the seated position the PO_{peak} on ergo-trainer was higher ($p < 0.05$) when compared to the gymnasium. This result suggests that the capacity to generate oscillations side to side during the short time sprint in seated position is not a factor that can increase the performance. It is possible that the static sprint start in the gymnasium requires concentration to maintain balance (especially at very low cycling velocities) which may disturb the cyclist. Also performing the static start in the seated position is not a standard strategy. Habitually in track competition during the sprint start or during the 1 000 m time trial the cyclist uses the standing position contrary to our sprint test.

In our study the relationships between force and velocity are similar to those previously reported.^{4, 14, 15, 17, 22-24} In the gymnasium conditions (seated and standing positions) F_o , F_{max} , and the time to obtain PO_{peak} were higher ($p < 0.05$) compared with the ergo-trainer conditions (+12%, +32%, and +41%, respectively). Compared to the ergo-trainer conditions, the F_{max} measured in the gymnasium represents a higher percentage of the F_o value obtained by the force-velocity relationships (64% and 84%, respectively). These results indicate that the cyclist can produce a higher force in the gymnasium conditions, that modifies the force-velocity relationships. The results obtained in laboratory conditions are different than the ones obtained in actual cycling. This suggests that sprint tests in actual cycling locomotion are more suitable (than laboratory conditions) for measuring the mechanical variables with higher accuracy.

The estimated PO_{mean} was linked to PO_{mean} ($r = 0.99$, $p < 0.001$). The 95% CI for the mean difference between the estimated PO_{mean} and the SRM measured PO_{mean} revealed that more than 70% of samples were inside this interval. This suggests that the model is valid to estimate the PO_{mean} during a short sprint in gymnasium. The basic physical equation used in this study could be used by coaches in a training program.

Our results indicate that the PO_{mean} was highly correlated ($r = 0.93$, $p < 0.001$) with the PO_{peak} and that PO_{peak} was 20% higher than PO_{mean} . The relationship between these 2 mechanical variables (Figure 6) could be easily used by a coach to estimate the PO_{peak} from the estimated PO_{mean} . The sprint test protocol used in this study could be used: 1) to determine the optimal gear ratio and crank length for the static start phase of the 1 000 m time trial or the Olympics team sprint, 2) as training test during the season for the

analysis of the force-velocity relationships. The force-velocity relationships can also be used to determine the resistive load for a strength training program. Indeed, F_0 corresponds to the maximal theoretical isometric force of a lower limb. To improve F_0 , Carpinelli *et al.*²⁵ suggest performing strength training between 70% to 100% of the maximal theoretical isometric force. Moreover, to take into account the bilateral deficit of the lower limb^{26, 27} the track cyclist should perform strength exercises alternatively with each lower limb.

Conclusions

In conclusion, the results of this study indicate that PO_{peak} , F_0 , and time to obtain PO_{peak} were different between laboratory and actual cycling conditions. To perform a valid estimation of the PO_{peak} in the seated and standing positions in laboratory it would be necessary to use the personal bicycle of the cyclist and a set-up that permits lateral oscillations. However, the better sprint tests seem to be those performed in actual cycling.

Acknowledgements.—Authors would like to thank Ms Catherine Capitan for her technical help in this study, and Mr Jean Noel Pemin for his advice.

References

- Craig NP, Norton KL. Characteristics of track cycling. *Sports-Med* 2001;31:457-68.
- Koning JJ, Bobbert MF, Foster C. Determination of optimal pacing strategy in track cycling with an energy flow model. *J Sci Med Sport* 1999;2:266-77.
- Ingen Shenau GJ, Koning JJ, de Groot G. The distribution of anaerobic energy in 1 000 and 4 000 metre cycling bouts. *Int J Sports Med* 1992;13:447-51.
- Vandewalle H, Peres G, Heller J, Panel J, Monod H. Force-velocity relationship and maximal power on a cycle ergometer: correlation with the height of a vertical jump. *Eur J Appl Physiol* 1987;56:650-6.
- Bosco C, Luhtanen P, Komi PV. A simple method for measurement of mechanical power in jumping. *Eur J Appl Physiol* 1983;50:273-82.
- Margarita R, Aghemo P, Rovelli E. Measurement of muscular power (anaerobic) in man. *J Appl Physiol* 1966;21:1662-4.
- Martin JC, Spirduso WW. Determinants of maximal cycling power: crank length, pedaling rate and pedal speed. *Eur J Appl Physiol* 2001;84:413-8.
- Grappe F, Candau R, Belli A, Rouillon JD. Aerodynamic drag in field cycling with special reference to the Obree's position. *Ergonomics* 1997;40:1299-311.
- Padilla S, Mujika I, Angulo F, Goiriena JJ. Scientific approach to the 1-h cycling world record: a case study. *J Appl Physiol* 2000;89:1522-7.
- Martin JC, Miliken DL, Cobb JE, McFadden KL, Coggan AR. Validation of a mathematical model for road cycling power. *J Appl Biomech* 1998;14:276-91.
- Bassett DR Jr, Kyle CR, Passfield L, Broker JP, Burke ER. Comparing cycling world hour records, 1967-1996: modeling with empirical data. *Med Sci Sports Exerc* 1999;31:1665-76.
- Jones SM, Passfield L. The dynamic calibration of bicycle power measuring cranks. In: Haake SJ, editor. *The engineering of sport*. Oxford: Blackwell Science; 1988.p.265-74.
- Passfield L, Doust JH. Changes in cycling efficiency and performance after endurance exercise. *Med Sci Sports Exerc* 2000;32:1935-41.
- Ravier G, Grappe F, Rouillon JD. Comparaison de deux méthodes d'analyse des variables maximales de vitesse, force et puissance dans l'évaluation fonctionnelle en karaté. *Science and Sport* 2003;18:134-40.
- Ravier G, Grappe F, Rouillon JD. Application of force-velocity cycle ergometer test and vertical jump tests in the functional assessment of karate competitor. *J Sports Med Phys Fitness* 2004;44(4):349-55.
- Fregly BJ, Zajac FE, Dairaghi CA. Bicycle drive system dynamics: theory and experimental validation. *J Biomech Eng* 2000;122:446-52.
- Buttelli O, Vandewalle H, Peres G. The relationship between maximal power and maximal torque-velocity using an electronic ergometer. *Eur J Appl Physiol* 1996;73:479-83.
- Caldwell GE, Li L, McCole SD, Hegberg JM. Pedal and crank kinetics in uphill cycling. *J Appl Biomech* 1998;14:245-59.
- Bland JM, Altman DG. Statistical methods for assessing agreement between two methods of clinical measurement. *Lancet* 1986;1:307-10.
- Reiser RJ, Maines JM, Eisenmann JC, Wilkinson JG. Standing and seated Wingate protocols in human cycling. A comparison of standard parameters. *Eur J Appl Physiol* 2002;88:152-7.
- Baker J, Brown E, Gary H, Glen P, Williams R, Davies B. Handgrip contribution to lactate production and leg power during high-intensity exercise. *Med Sci Sports Exerc* 2002;34:1037-76.
- Arsac LM, Belli A, Lacour J-R. Muscle function during brief maximal exercise: accurate measurements on a friction-loaded cycle ergometer. *Eur J Appl Physiol* 1986;74:100-6.
- Hintzy F, Belli A, Grappe F, Rouillon J-D. Optimal pedalling velocity characteristics during maximal and submaximal cycling in humans. *Eur J Appl Physiol* 1999;79:426-32.
- Hintzy F, Belli A, Grappe F, Rouillon J-D. Effet de l'utilisation de pédales automatiques sur les caractéristiques mécaniques mesurées lors de sprints sur cycloergomètre non-isocinétique. *Science and Sports* 1999;14:137-44.
- Carpinelli RN, Otto RM. Strength training. Single *versus* multiple sets. *Sports Med* 1998;26:73-84.
- Coyle EF, Feiring DC, Rotkis TC, Cote RW 3rd, Roby FB, Lee W *et al.* Specificity of power improvements through slow and fast isokinetic training. *J Appl Physiol* 1981;51:1437-42.
- Howard JD, Enoka RM. Maximal bilateral contractions are modified by neurally mediated interlimb effects. *J Appl Physiol* 1991;70:306-16.